



Smarter.Safer.Greener.



AREA LIGHTING

# 8 million

FLOOD LIGHTS POINTS

More than  
**80000**  
Mast Installations

More than  
**1 MILLION**  
Mast Lighting

More than  
**5000**  
Infrastructure facilities  
illuminated

**9** Decades  
of  
Legacy

 Inhouse  
R&D and  
Manufacturing  
Facilities

 Concept  
to  
Care

# BUILDING INDIA'S INFRASTRUCTURE



Rapid infrastructure development in the country spans across various sectors, each contributing to the nation's progress by creating world class infrastructure like airports, ports, railway hubs, manufacturing hubs, smart cities deployment with advanced facilities and efficient public services.

Bajaj Lighting, a pioneer in the lighting industry, has been instrumental in the journey of nation building for over eight decades. Our cutting-edge & innovative products ensure energy efficiency, durability, and optimal illumination, making spaces more accessible and secure. Bajaj Lighting continues to play a pivotal force, driving advancements and setting benchmarks in the lighting industry.



## PRODUCTIVITY & SAFETY

Challenging environments like ports, shipyards, and similar applications demand enhanced visibility to significantly improve productivity and safety. This requires bright, uniformly lit spaces which reduces shadows, blind spots, allowing workers to navigate and perform tasks with greater accuracy and speed. Consequently, superior lighting directly contributes to a safer, more productive work environment.

### IMPROVED VISIBILITY

Enhances safety by reducing the risk of accidents and aiding ease of operations.

### OPTIMISED SURVEILLANCE

Enhance surveillance activities, protecting lives and providing added security to infrastructure.

## OPTIMISED EFFICIENCY

Amidst global power shortages, the importance of energy-saving measures is heightened, particularly in floodlights, known for their high-power consumption. Higher efficiency LED products and smart solutions mitigate power consumption, ensuring sustained illumination during scarcity. Intelligent controls adapt to resource constraints, maximizing light output while conserving energy, vital for reliability in challenging conditions.

### HIGH EFFICACY

Maximizing illumination while minimizing energy consumption and ensuring sustainability.

### SMART SOLUTIONS

Adapt to environmental factors, optimizing energy usage, enhancing safety, and offering customizable lighting options for diverse needs.



## SOLUTIONS TO LIGHT POLLUTION

Light pollution is a significant environmental issue with far-reaching impacts on human health, wildlife, energy consumption, astronomical observation, safety, and economics. Hence, addressing light pollution is essential for fostering a healthier, more sustainable environment.

Area lighting, when designed and implemented thoughtfully, can play a pivotal role in reducing this problem. By focusing on high-performance precision optics and intelligent design, modern flood lighting solutions minimize unnecessary light spill and glare, ensuring that light is directed exactly where it is needed.

### PROTECT ECOSYSTEM & WILDLIFE

Use of precision optics can help to minimize disruption to nocturnal wildlife, support natural behaviors of wildlife including birds and insects who are highly sensitive to artificial light.

### ENHANCES RESIDENT HEALTH

Minimising glare and light trespass helps improve quality of life while preserving the natural beauty of the night sky.



## LOWER TOTAL COST OF OWNERSHIP

Every user strives to optimize cost of ownership while ensuring safety and security. A well-engineered lighting solutions with high efficacy and durability can reduce overall costs significantly. Investing in durable, efficient lighting minimizes need of frequent maintenance and replacements, leading to substantial long-term savings.

### DURABILITY AND LONGEVITY

Reduces maintenance and replacement costs.

### HIGHER ENERGY SAVING

Enhanced efficacy and precision optics lower energy consumption.

### COST OPTIMISATION

Superior optics and design reduce overall project costs.

### EFFICIENT LIGHTING

High performance without compromising quality.



# OUR PRODUCT DESIGN PHILOSOPHY

Beta photometry is significant in flood lighting applications as it ensures precise, efficient, compliant lighting solutions that enhance safety, visibility, and energy efficiency. This calls for an effective, optimised lighting design and use of efficient flood light luminaires with high precision & performance optics.

Given the complexity and higher maintenance costs associated with floodlights installed at greater heights, the product design must account for these factors to ensure a long, maintenance-free service life and perform consistently over time.



## QUALITY OF LIGHT

High-performance precision optics not only ensure optimal brightness, uniformity, and glare-free illumination but also create safer, more productive spaces, minimizing light pollution meeting lighting standards.



## HIGH ENERGY EFFICIENCY & LOW CARBON FOOTPRINT

Use of high efficacy LED chip combined with high performance optics ensures maximum energy efficiency and low carbon footprint.



## RELIABILITY & DURABILITY

Well engineered & robust construction of our flood lights helps them withstand harsh weather conditions, other environmental factors resulting in long-term savings by reducing the need for frequent replacements and repairs.



## SMART & FUTURE READY

Our future-ready product design ensures compatibility and integration with the latest smart solutions offering enhanced control & comfort to the users.



## SUSTAINABLE

Use of materials and manufacturing processes that minimize environmental impact. Recyclability, use of renewable resources ensures reduction of carbon footprint throughout the product lifecycle.

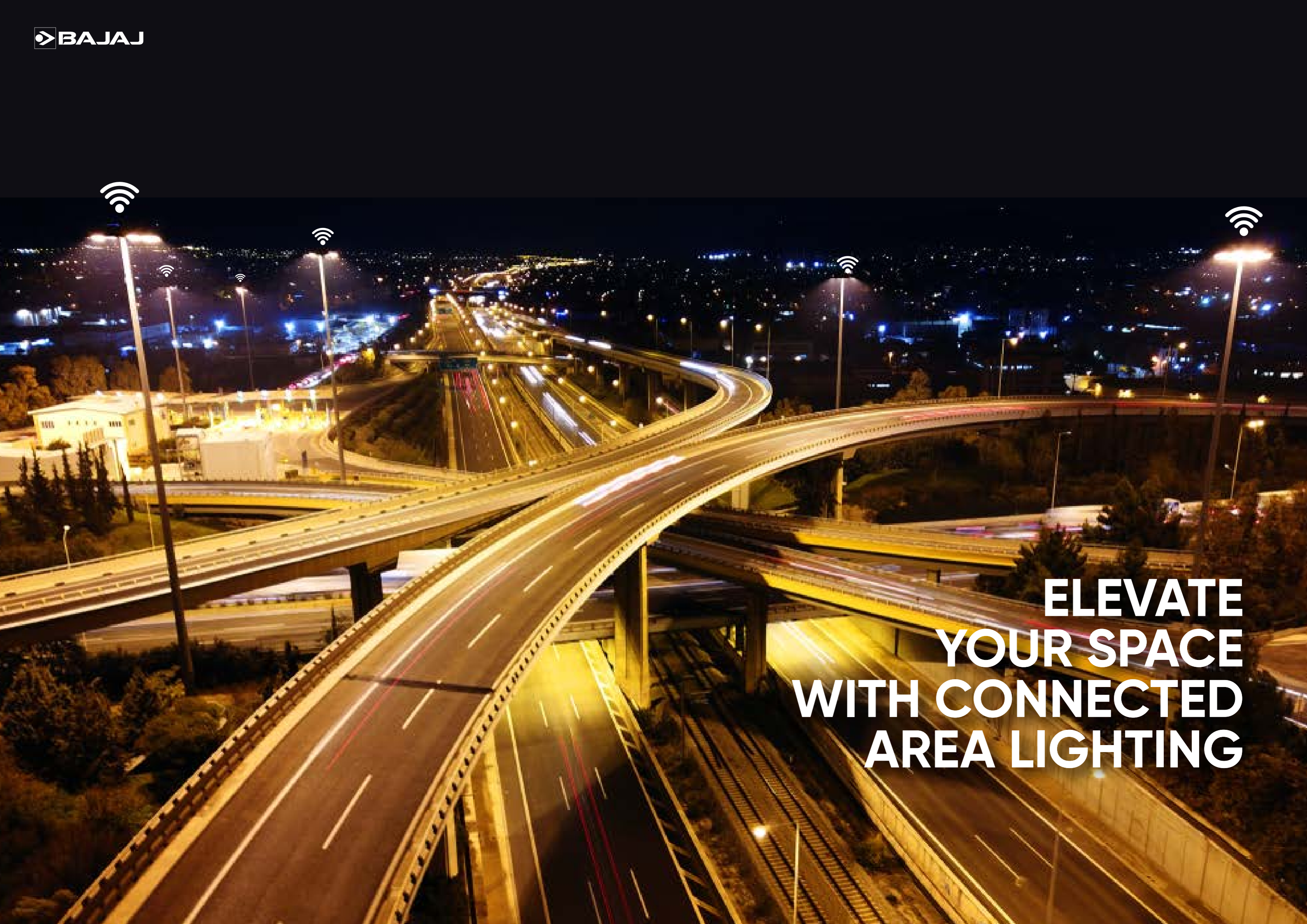

**ELEVATE  
YOUR SPACE  
WITH CONNECTED  
AREA LIGHTING**



**CITISOL**  
SMART LIGHTING  
MANAGEMENT SOLUTION

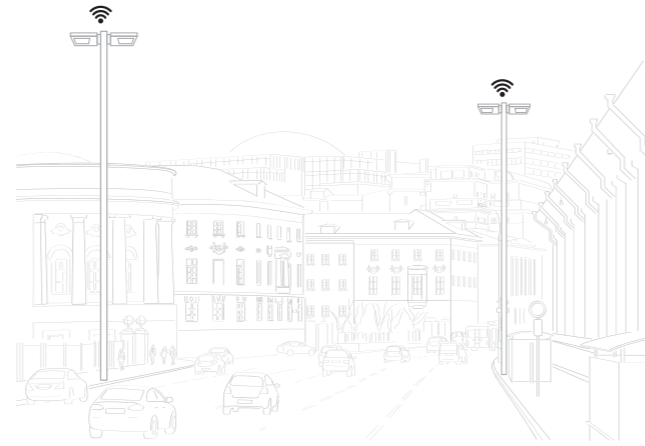

## SOLUTION FEATURES

CitiSol offers various control options to its users which thereby have an impact on the experience of the end users.



### DIMMING PROFILE SETTING

Adjust light levels based on real-time conditions based on usage patterns.



### CENTRAL COMMAND CENTRE INTEGRATION

CitiSol provides full remote management for your entire lighting infrastructure. Open architecture and Open API allow secure integration to any of your preferred 3rd party application.



### ON DEMAND

Let there be light when its needed the most, and that control needs to be executed at the click of a button. CitiSol has on demand, and near real time control of switching flood lights on and off.



### SCHEDULING

Keeping energy efficiency and maintenance efficiency as the uber goal of the platform solution, CitiSol assures schedule configuration as per customer needs.



### ALERTS AND NOTIFICATIONS

CitiSol offers proactive and customizable notifications to help take time critical decisions. CitiSol is designed for the local asset management & maintenance crews, the Alerts tool offers near real-time status information of every individual or group of luminaires. Faults and outages are automatically registered, and notifications are sent to the assigned person to undertake action.



### REPORTS AND CHARTS

The CitiSol platform has a central dashboard that helps you to track your infrastructure's lighting performance, status, energy consumption and savings over different locations and customizable periods of time. Device network analytics is also an integral part of this tool.

## KEY FEATURES



Group Control



Group Dimming



Individual Control



Command Control Solutions



Technology - Agnostic Solutions



# AREA LIGHTING

Brighter Spaces

Be ensure maximum visibility and safety across all types of large spaces with our advanced area lighting solutions. Our lighting systems provide consistent and reliable illumination.

Engineered for durability and energy efficiency, our solutions enhance operational efficiency and safety in any environment.

# PRAZE

For optimum performance

Praze is an aesthetic flood light range with robust construction & optimum performance. Ranging from lower wattage to high wattage it caters to varied area lighting applications.



### Robust Construction & Appealing Aesthetics

Well engineered pressure die-cast aluminum housing with an appealing design.



### Best in Class System Efficacy

with upto 120 lumens per watt.



### Superior Optical Performance

With non-yellowing secondary lens optics and toughened glass.

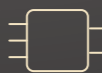

### High Performance Driver

Potted driver with inbuilt surge, voltage, open/short circuit protection for long & maintenance free service life.



IP66  
IK07



4KV  
Internal Surge  
Protection -  
10kV External SPD



THD<10%  
PF>0.95

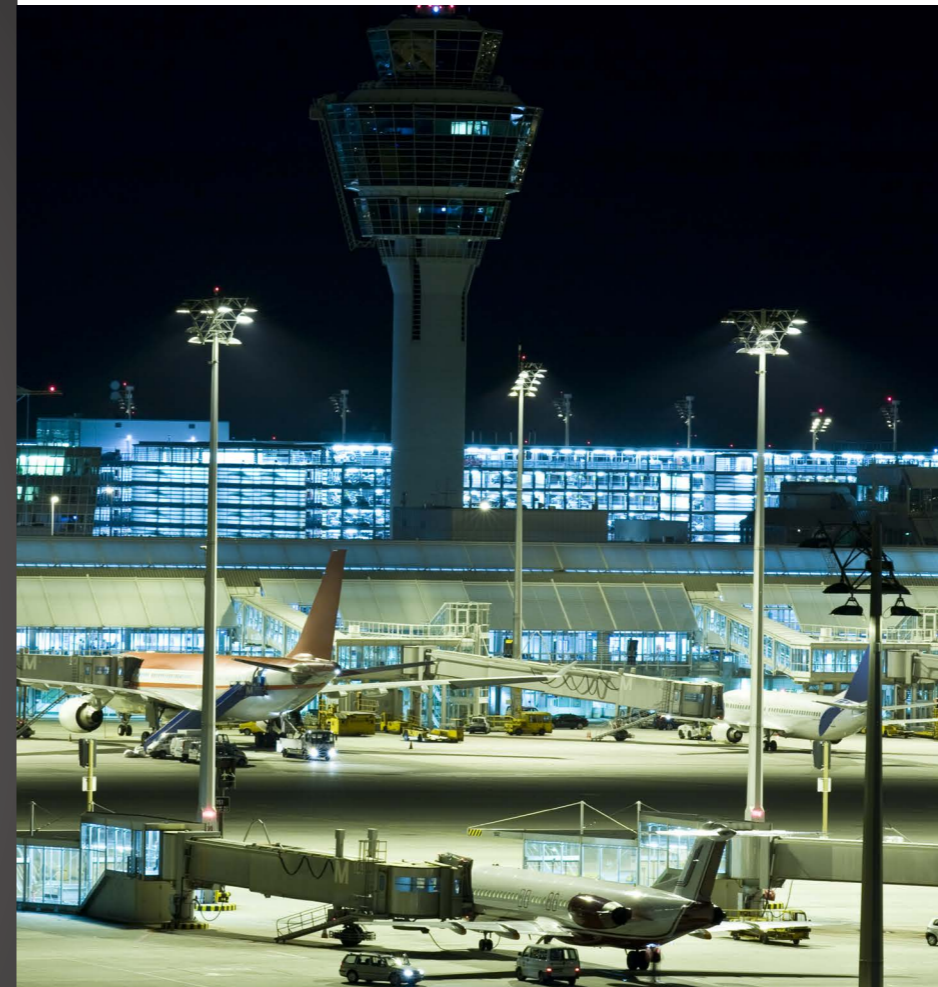

### Applications



Parking  
Area



Small  
Junctions



Periphery  
Lighting

### Product Diagram

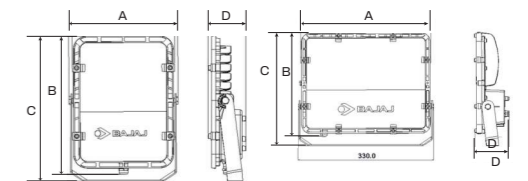

### Polar Curves

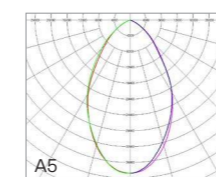
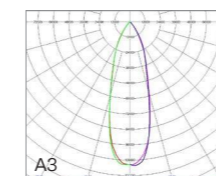

### Specifications & Dimensions

Wattages	Product Description	Voltage	CCT	System Current (Amp.)	Dimensions			
					A	B	C	D
80W	PRAZE F 96L WH NB-A5 TG SD	240	5700	0.33	200	252	264	70
100W	PRAZE F 120L WH NB-A5 TG SD	240	5700	0.42	200	252	264	70
120W	PRAZE F 144L WH NB-A5 TG SD	240	5700	0.51	200	252	264	70
150W	PRAZE F 180L WH NB-A5 TG SD	240	5700	0.65	316	252	275	85
180W	PRAZE F 216L WH NB-A5 TG SD	240	5700	0.76	316	252	275	85
200W	PRAZE F 240L WH NB-A5 TG SD	240	5700	0.85	316	252	275	85
250W	PRAZE F 300L WH NB-A5 TG SD	240	5700	1.10	318	375	417	86
300W	PRAZE F 360L WH NB-A5 TG SD	240	5700	1.30	318	375	417	86
350W	PRAZE F 420L WH NB-A5 TG SD	240	5700	1.48	318	375	417	86
400W	PRAZE F 480L WH NB-A5 TG SD	240	5700	1.75	318	375	417	86

- A3: 30° beam; A5: 60° beam.
- Also available in warm white (3000K CCT).

# GLEAM GRAND

Light that never rests

Bajaj Gleam Grand stands by its name, grandeur in performance and superior technology. Modular design and its unique form factor enables wider coverage & enhanced uniformity. Its form factor also complements the circular lantern carriage design of the mast making it a perfect solution for multiple applications areas.



### Thoughtfully Designed & Engineered

Modular design with unique form factor enabling wider coverage and enhanced uniformity. Meticulously engineered air pockets, facilitates superior air circulation & enhanced thermal management ensuring performance reliability and durability.



### Best in Class System Efficacy

With upto 120 lumens per watt.



### Superior Optical Performance

With non-yellowing polycarbonate secondary optics.



### High Performance Driver

With built-in surge, over voltage, open/short circuit protection for longer service life.



IP66  
IK08



4kV  
Internal Surge  
Protection -  
10kV External SPD



THD<10%  
PF>0.95



### Applications



Railway  
Yards



Airports



Ship Container  
Yards



Large  
Junctions



Warehouses

### Product Diagram

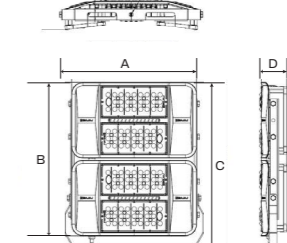
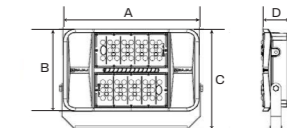

### Polar Curves

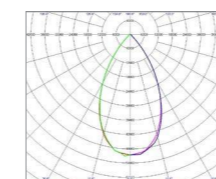

### Specifications & Dimensions

Wattages	Product Description	Voltage	CCT	System Current (Amp.)	Dimensions A	Dimensions B	Dimensions C	Dimensions D
150W	GLEAM-G F 180L WH NB-A5 PC SD	240	5700	0.65	328	198	241	66
200W	GLEAM-G F 240L WH NB-A5 PC SD	240	5700	0.87	328	198	241	66
250W	GLEAM-G F 300L WH NB-A5 PC SD	240	5700	1.10	328	401	470	66
300W	GLEAM-G F 360L WH NB-A5 PC SD	240	5700	1.32	328	401	470	66
350W	GLEAM-G F 420L WH NB-A5 PC SD	240	5700	1.53	328	401	470	66
400W	GLEAM-G F 480L WH NB-A5 PC SD	240	5700	1.75	328	401	470	66

# GLATT

City's ultimate outdoor lighting companion

Presenting, Glatt LED Floodlight, a high-performance luminaire with unique prismatic design and superior aesthetic appeal that enhances every need of illumination for various applications. It is an extremely durable, energy efficient floodlight that is compact and light weight, making it a perfect choice.

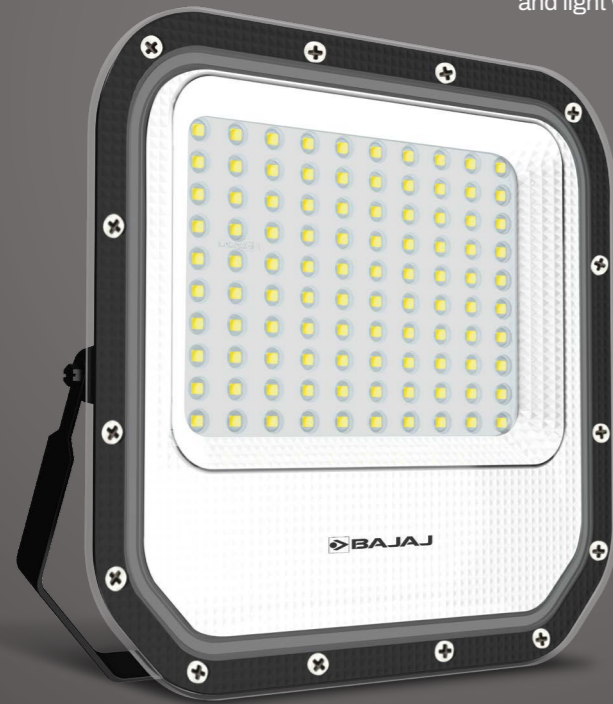

**Superior & Apealing Aesthetics**  
Epoxy powder coated pressure die-cast aluminium housing.



**Best in Class System Efficacy**  
With upto 120 lumens per watt.



**Superior Optical Performance**  
With non-yellowing polycarbonate secondary optics.

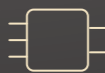

**High Performance Driver**  
With built-in surge, over voltage, open/short circuit protection for longer service life.



IP66  
IK07



**4kV**  
Internal Surge  
Protection -  
(+10kV for  
100W & above)



THD<10%  
PF>0.95



## Applications



## Product Diagram

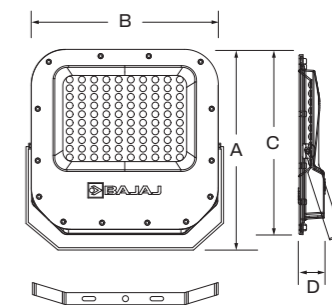

## Specifications & Dimensions

Wattages	Product Description	Voltage	CCT	System Current (Amp.)	Dimensions			
					A	B	C	D
30W	GLATT MT 36L WH PO PC SD	240	5700	0.145	180	175	155	37
50W	GLATT MT 60L WH PO PC SD	240	5700	0.241	200	208	193	37
80W	GLATT MT 96L WH PO PC SD	240	5700	0.386	265	260	250	37
100W	GLATT MT 120L WH PO PC SD	240	5700	0.482	265	260	250	37
120W	GLATT MT 144L WH PO PC SD	240	5700	0.579	312	305	295	37
150W	GLATT MT 180L WH PO PC SD	240	5700	0.724	312	305	295	37



# SPORTS LIGHTING

Brilliant Performance

Whether it's a community field or a local mini stadium, our lighting systems provide the perfect illumination for athletes and spectators alike, ensuring a brilliant experience every time the lights come on.

# AMAZE PLUS

Reinventing natural light for outdoor space

With high precision optical performance, the Bajaj Amaze Plus is an ideal solution for high power applications most lighting and smaller sports infrastructure.

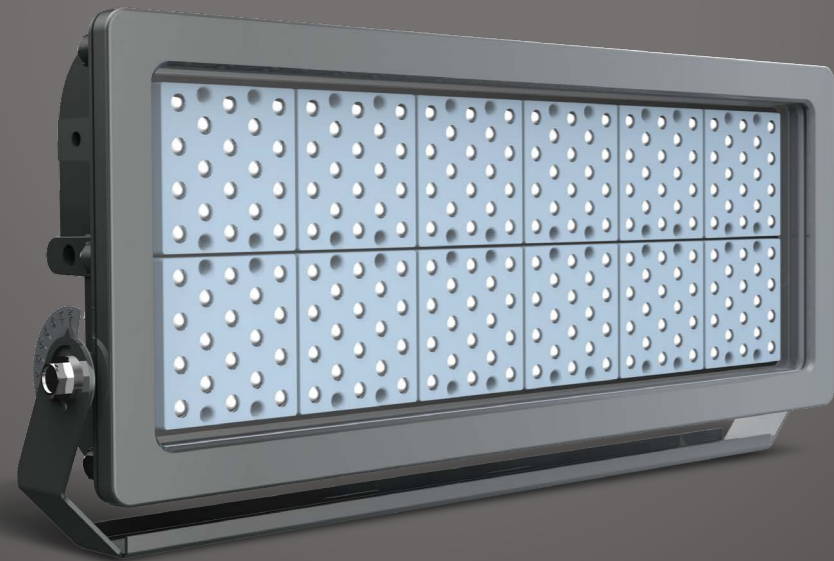

### Robust Construction

Epoxy powder coated pressure die-cast aluminium housing.



### Best in Class System Efficacy

With upto 120 lumens per watt.



### Superior Optical Performance

With non-yellowing secondary lens optics and toughened glass.



### High Performance Driver

Potted driver with inbuilt surge, voltage, open/short circuit protection for long & maintenance free service life.



IP66  
IK08



4KV  
Internal Surge  
Protection -  
10kV External SPD



THD<10%  
PF>0.95



### Applications



Railway  
Yards



Mast  
Lighting



Container  
Yards



Small  
Stadium

### Product Diagram

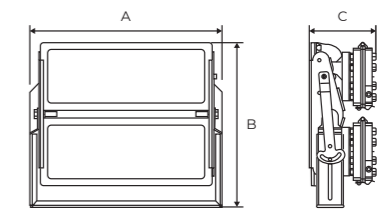
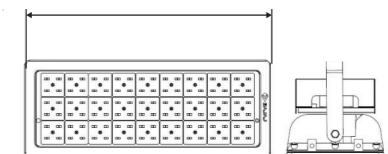

### Polar Curves

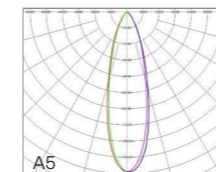
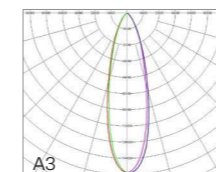
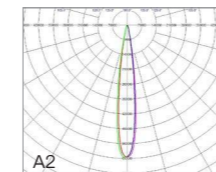

### Specifications & Dimensions

Wattages	Product Description	Voltage	CCT	System Current (Amp.)	Dimensions		
					A	B	C
500W	AMPL F 600L WH NB-A2 TG SD	240	5700	2.2	530	210	210
500W	AMPL F 600L WH NB-A3 TG SD	240	5700	2.2	530	210	210
500W	AMPL F 600L WH NB-A5 TG SD	240	5700	2.2	530	210	210
1000W	AMPL F 1.2KL WH NB-A2 TG SD	240	5700	4.4	640	756	270
1000W	AMPL F 1.2KL WH NB-A3 TG SD	240	5700	4.4	640	756	270
1000W	AMPL F 1.2KL WH NB-A5 TG SD	240	5700	4.4	640	756	270

- A2: 15° beam; A3: 30° beam; A5: 60° beam.
- Also available in warm white (3000K CCT).



# TUNNEL LIGHTING

Optimal Visibility for  
Every Tunnel, Every Time

Designed for the demands of tunnel environments, our systems provide reliable illumination, enhancing driver visibility and safety. Engineered for durability and energy efficiency, our lighting solutions are the ideal choice for any tunnel infrastructure.

# TUNEL

Maximum safety. Maximum comfort.

A well thought innovative design for seamless continuous rows and with best lighting values. Bajaj Tunnel is the optimum solution for traffic safety and maximum visual comfort in tunnels.



### Well Thought-out Design

Ensuring traffic safety across all zones of tunnel.



### Best in Class System Efficacy

With upto 130 lumens per watt.



### Simple & Compact

The compact luminaire with great flexibility ensures easy installation and maintenance.

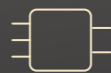

### High Performance Driver

With built-in surge, over voltage, open/short circuit protection for longer service life.



IP66  
IK08



4KV  
Internal Surge  
Protection -  
10kV External SPD



THD<10%  
PF>0.95



## Applications



Tunnels

## Product Diagram

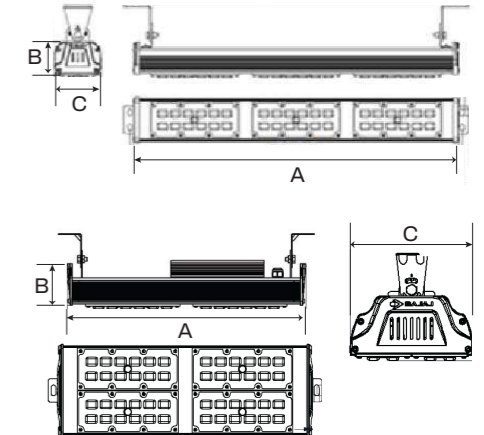

## Polar Curves

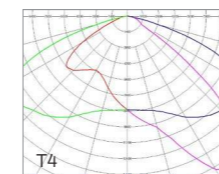
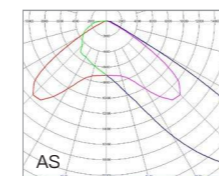

## Specifications & Dimensions

Wattages	Product Description	Voltage	CCT	System Current (Amp.)	Dimensions		
					A	B	C
45W	BJTU S 58L NW AS PC SD	240	5700	0.19	207	64	90
80W	BJTU S 108L NW AS PC SD	240	5700	0.35	433	64	90
150W	BJTU S 202L NW AS PC SD	240	5700	0.72	630	64	90
180W	BJTU S 243L NW AS PC SD	240	5700	0.86	439	77	157
240W	BJTU S 324L NW AS PC SD	240	5700	1.15	637	77	157
300W	BJTU S 390L NW AS PC SD	240	5700	1.44	637	77	157



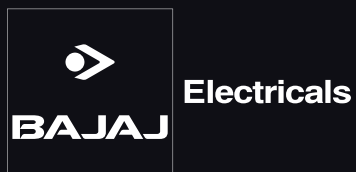

27th Floor, One Unity Center, Tower 4, Senapati Bapat Marg, Prabhadevi (West), Mumbai – 400013.  
Tel.: 022-2406 4400 | E-mail: illumination@bajajelectricals.com | www.bajajelectricals.com

[f /BajajElecBiz](#) [x /BajajElecBiz](#) [@ /bajajelecbiz](#) [in /BajajElectricals](#)

\* Images of the products shown are for representation purpose only and the actual colour/size may vary.